

1

2

3

4

5

REVISIONS

REV	DESCRIPTION	DATE	APPROVED
A	INITIAL RELEASED	Oct, 19th 2006	TQ

D

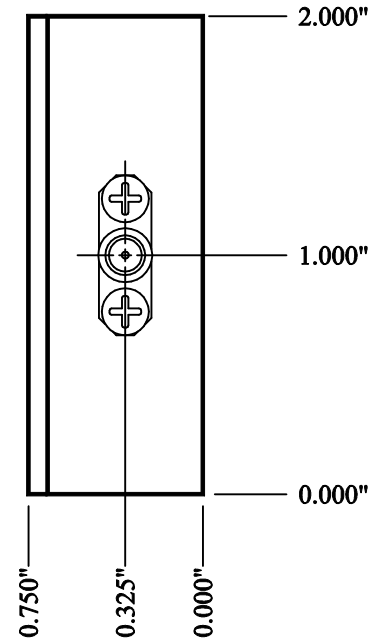
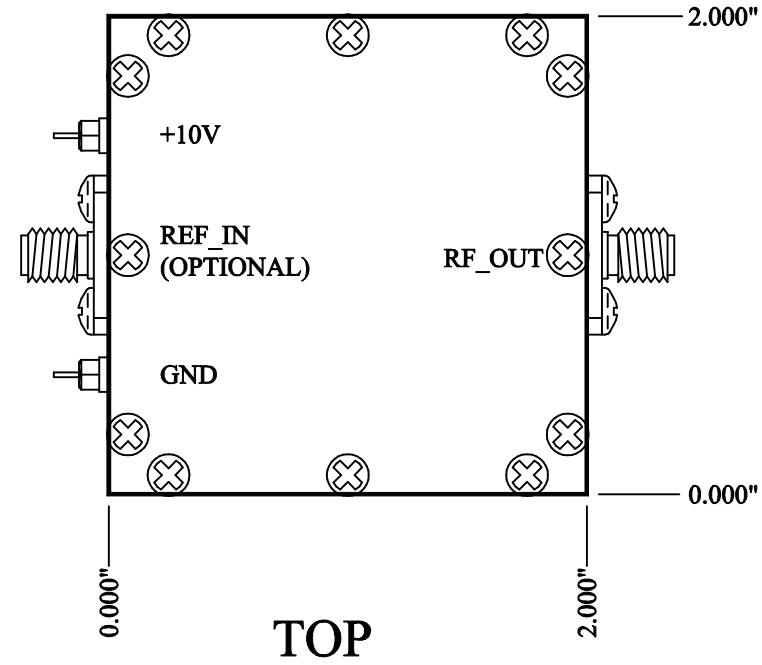
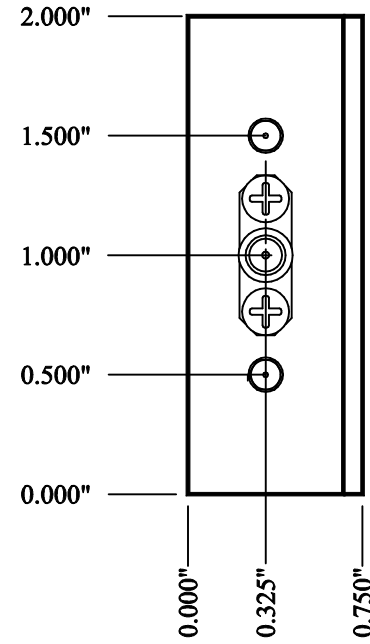

C

2-56 Drill & Tap  
0.200" Deep, 4 Places

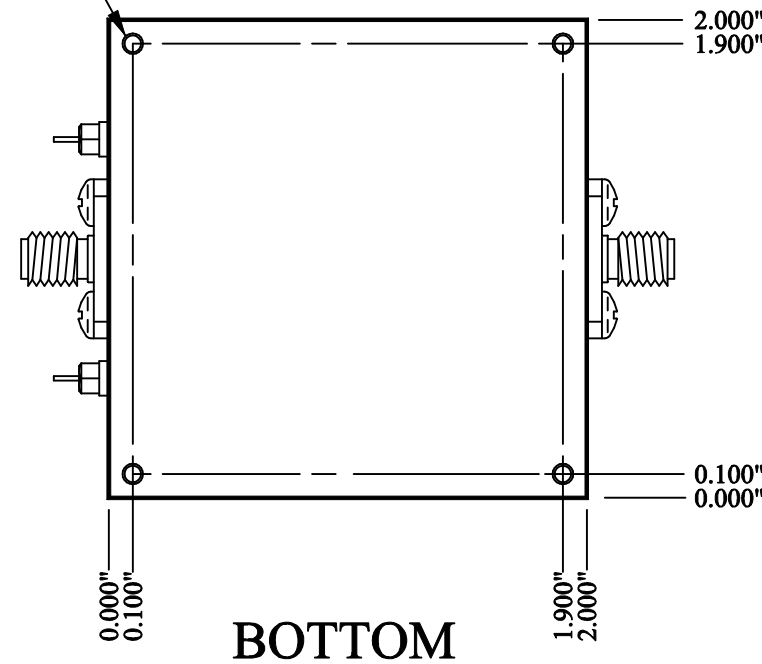

Note, unless otherwise specified

1. Dimensions are in inches
2. Tolerance:  
.xx = 0.01"  
.xxx = 0.005"  
.xxxx = 0.002"
3. Standard surface finish
4. Material: T6068 Aluminum Chem Conversion Coat

B

A

NOT TO SCALE

General Electronic Devices  
San Marcos, California

Title		
LMPL_F MECHANICAL DRAWING		
Size A	DWG NO. 11003	Rev. A
Drawn By: TQ	Appr. By:	Date: Oct, 19th 2006